

**Arvand**®

Since 1960

Florence





Florence

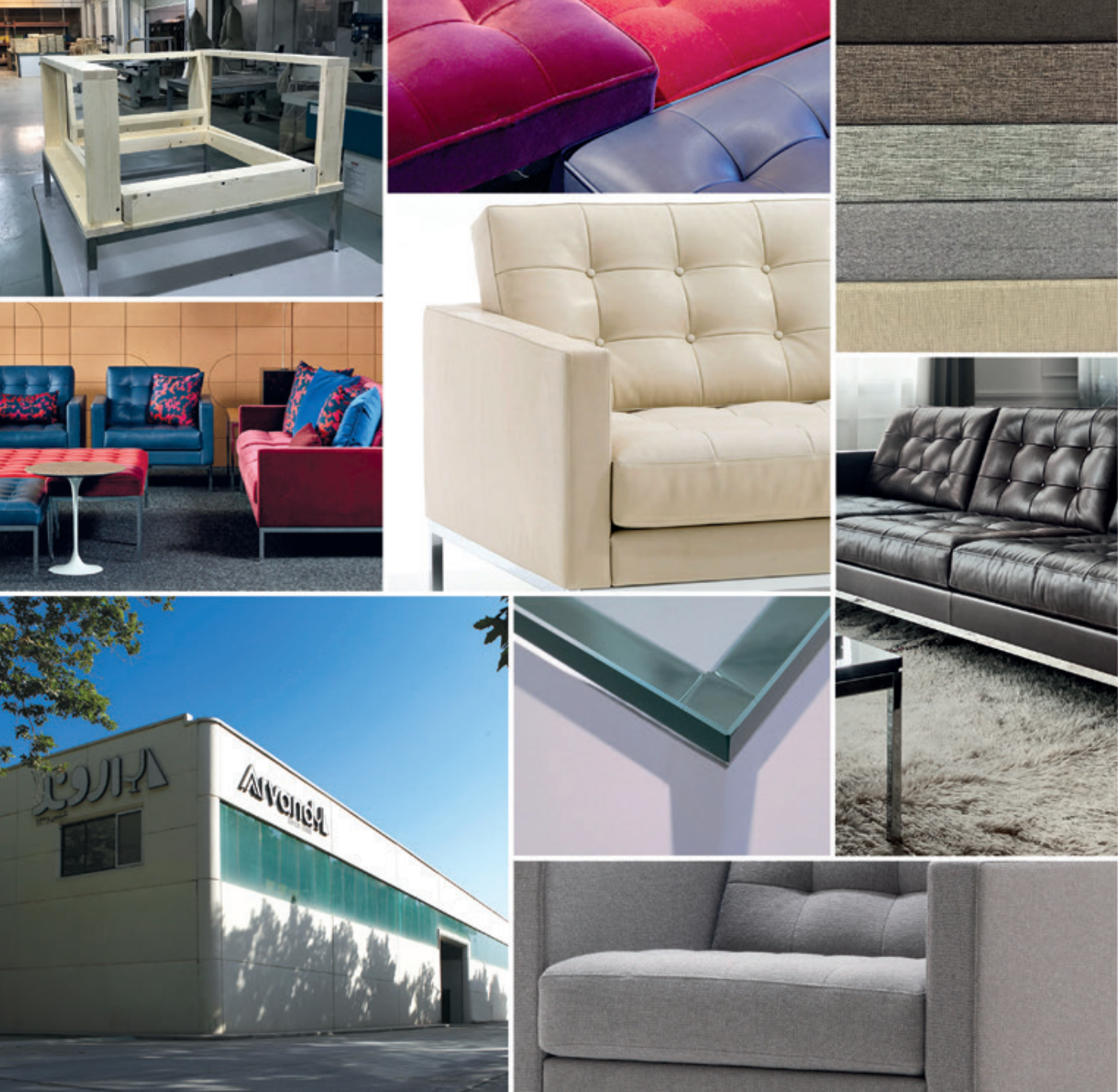

# Arvand®

Since 1960

60 years ago we started from a modest beginning, designing and manufacturing metal products for offices, hospitals as well as various kinds of swivel chairs for conference halls. Even from the very beginning, we manufactured products that conformed to international standards. All of the parts except Gas springs were manufactured locally using the highest quality raw material. Putting the safety and health of users before everything else, designing our products according to the latest ergonomic principles. During the past 20 years our hard work and attention to the safety of customers paid off and we are now transformed into an industrial group, with craftsmen capable of manufacturing almost all required parts equal to the highest international standards within the group, allowing us to provide customers with 3 years guarantee. Today Arvand high standards of workmanship have not only put us among the leading chair manufacturers in the country but an early start 60 years ago places us among the pioneers of this field in Iran. We hope to have an ever-increasing effect on the promotion of this industry inside the country.









FLORENCE  
Lounge Chair



# FLORENCE

Lounge Chair  
Metal series



4030 M



4034 M



4032 M

# FLORENCE

Lounge Chair  
Wood series



4030 W



4034 W



4032 W



Arvand®  
Since 1960







FLORENCE  
B e n c h



# FLORENCE

## Bench Metal Series



4023 M



4021 M



4022 M

# FLORENCE

## Bench Wood Series



4023 W



4021 W



4022 W





MAKE THINGS  
H A P P E N





FLORENCE  
T a b l e





# FLORENCE

Table  
Metal Series



5019 MW



5020 MG



5021 MS

# FLORENCE

Table  
Wood Series



5019 WW



5020 WG



5021 WS



PROVIDING  
CREATIVITY



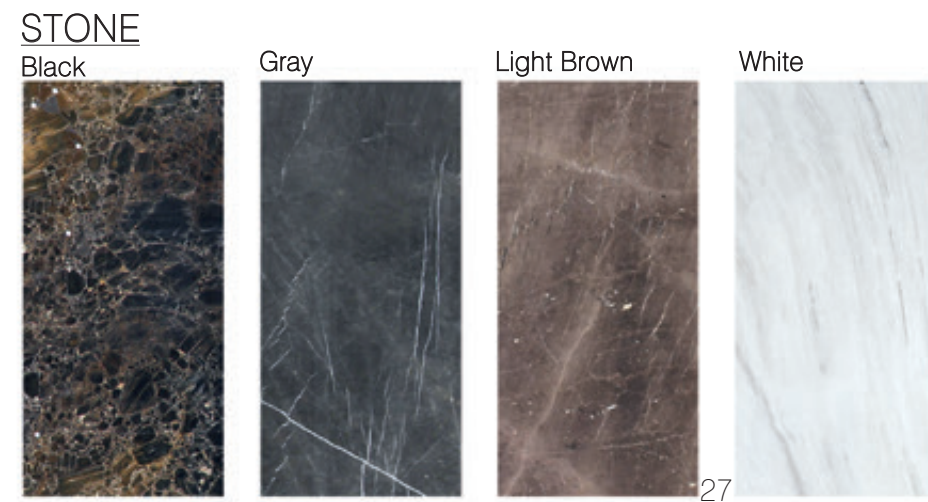
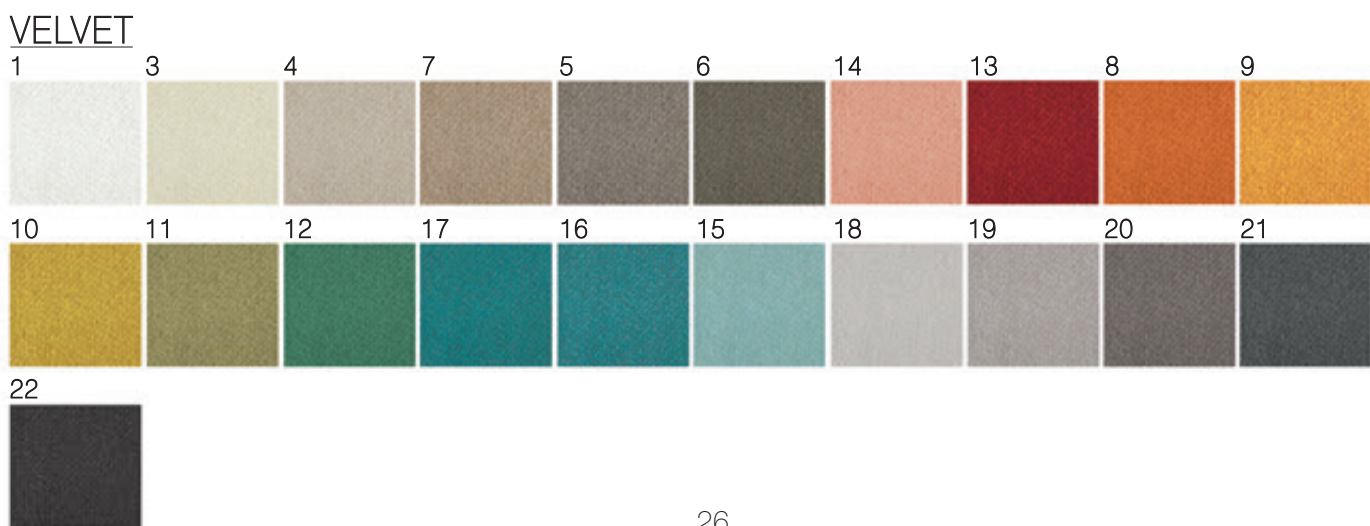
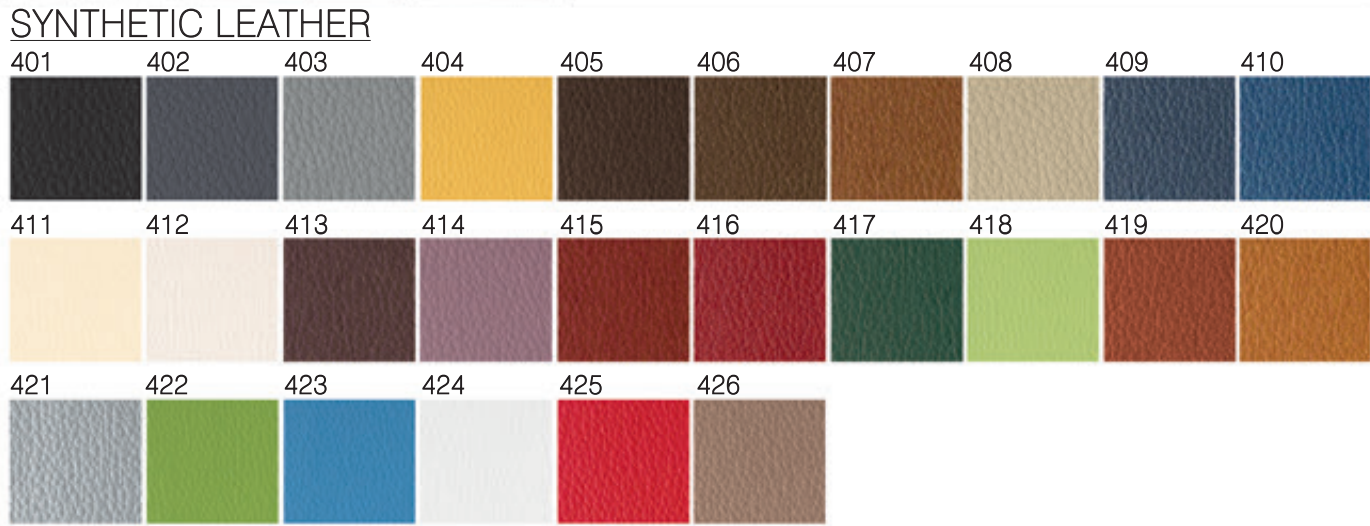
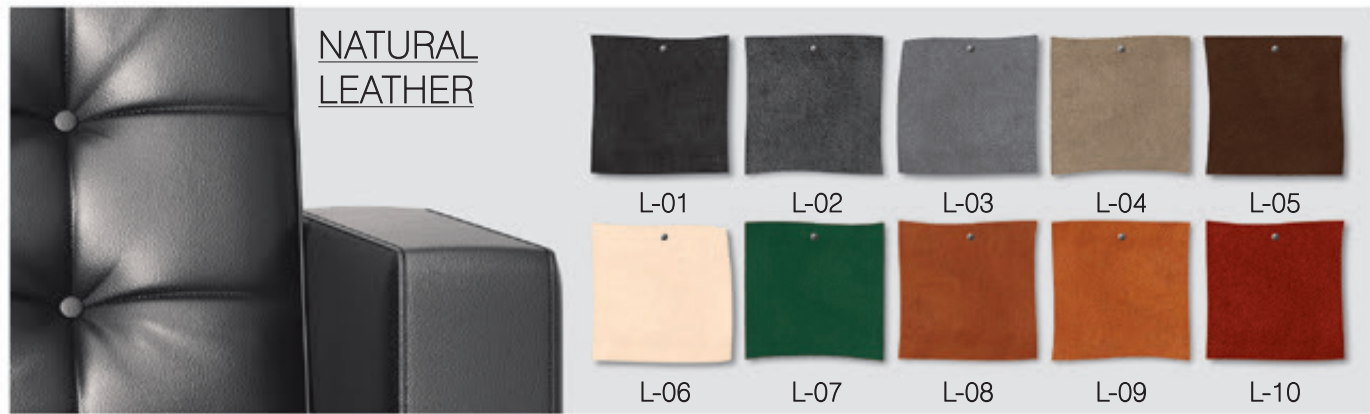

LOUNGE CHAIR

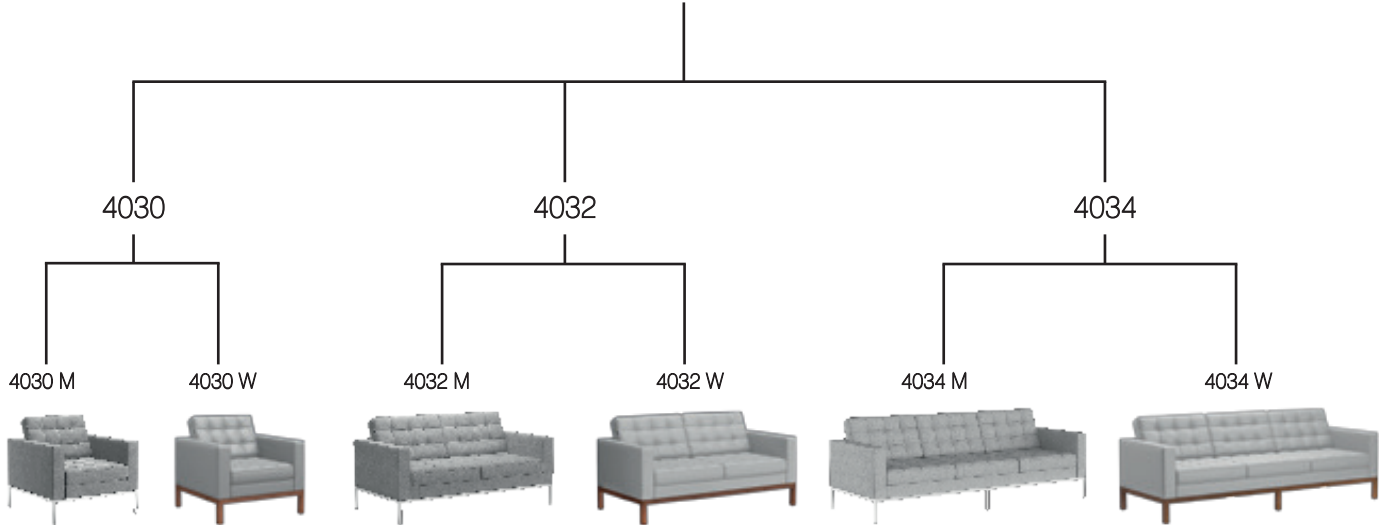

TABLE

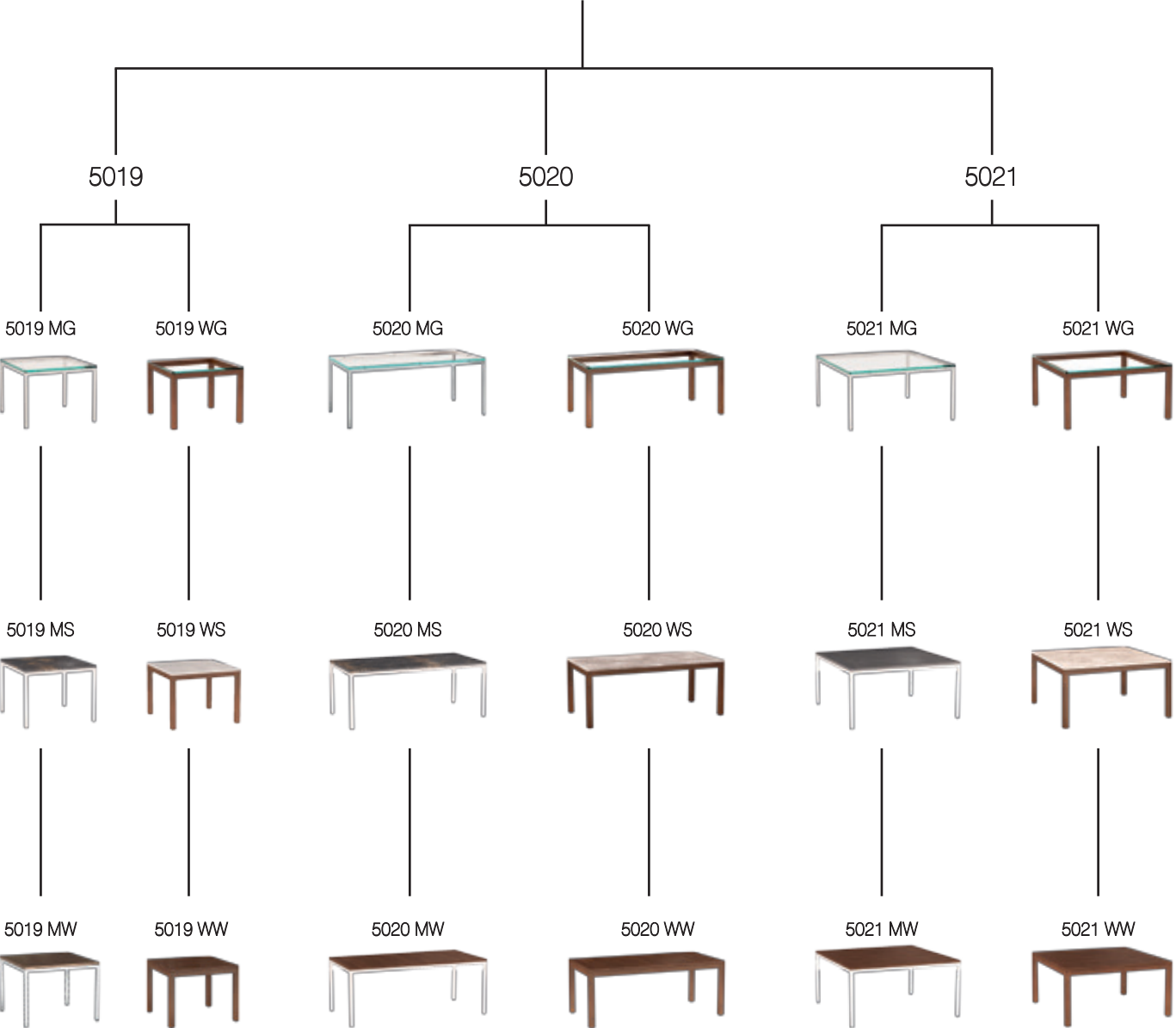

BENCH

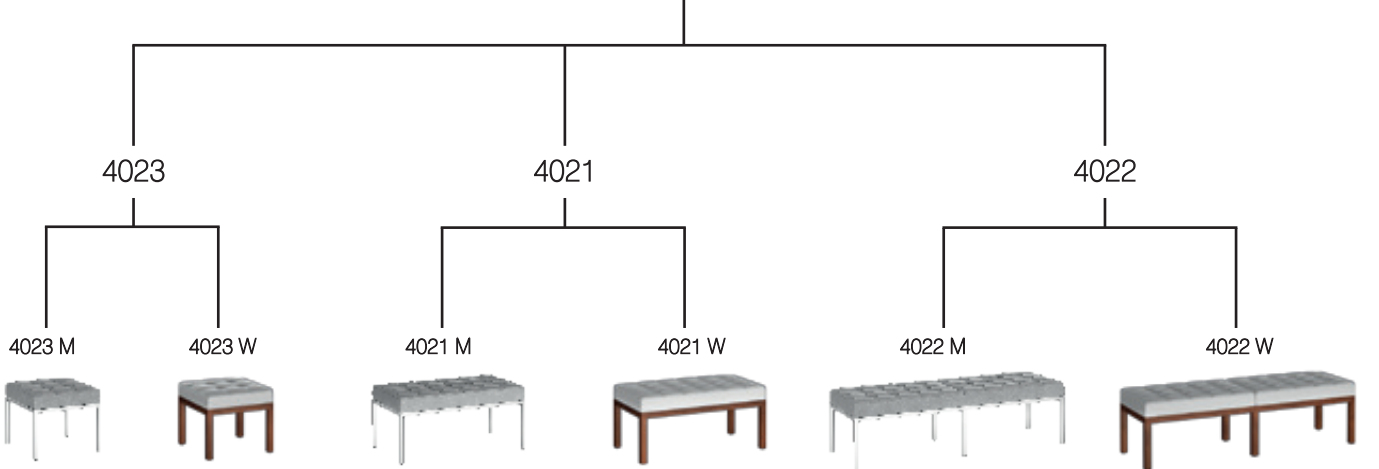



# Arvand Florence Dimension

## Lounge Chair

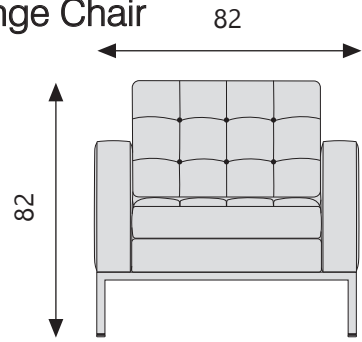

82

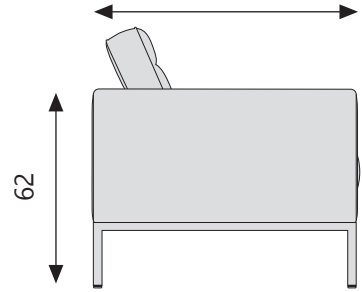

62

4030

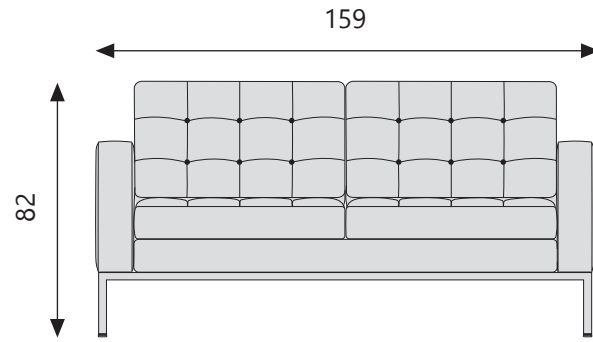

159



62

82

4032

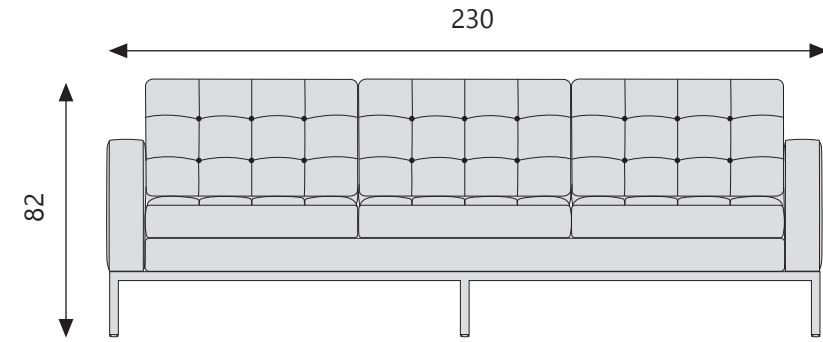

230

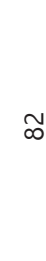

62

82

4034

## Bench

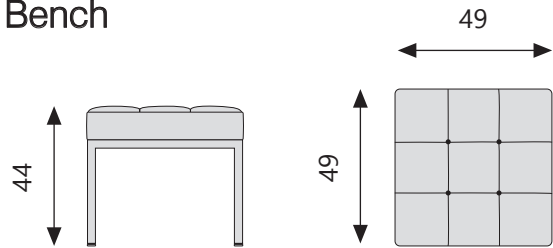

44

49

4023

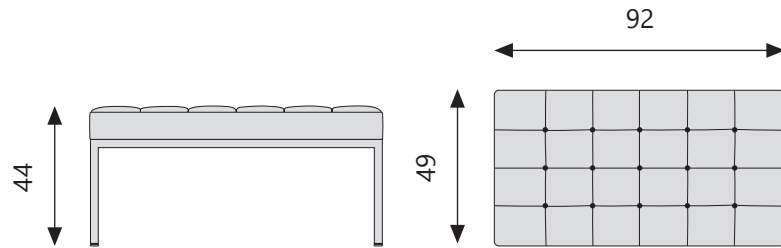

44

92

4021

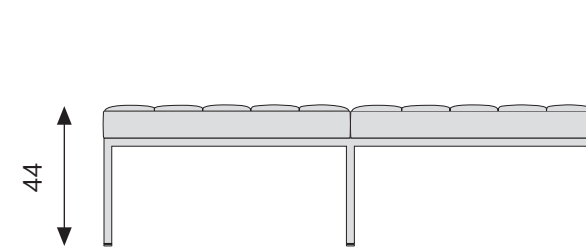

44

4022

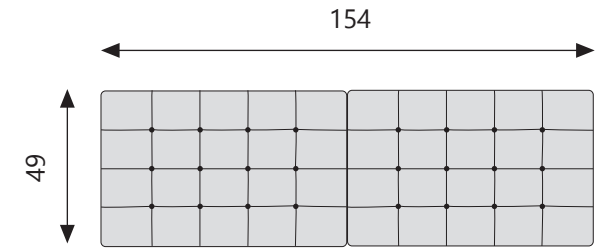

154

49

## Table

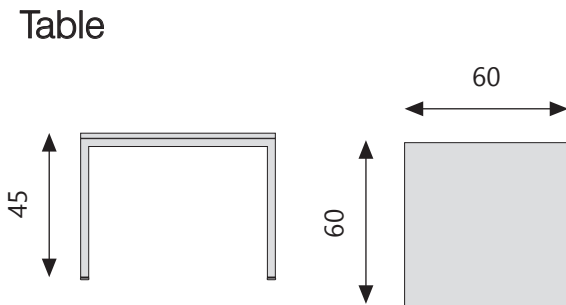

45

60

5019

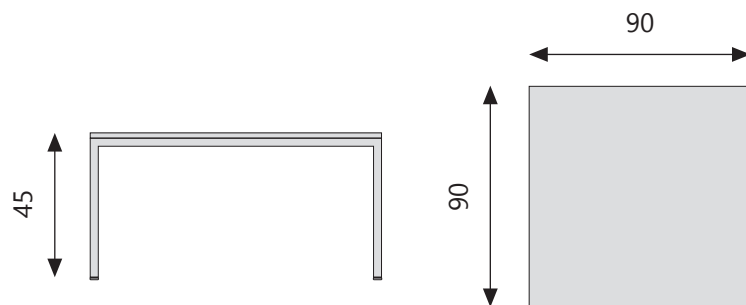

45

90

5021

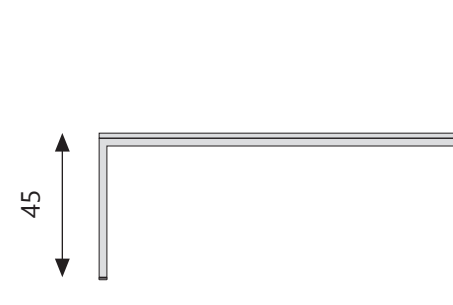

45

5020

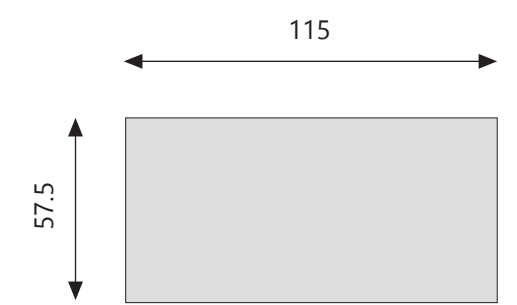

57.5

115

# Furniture Arrangement

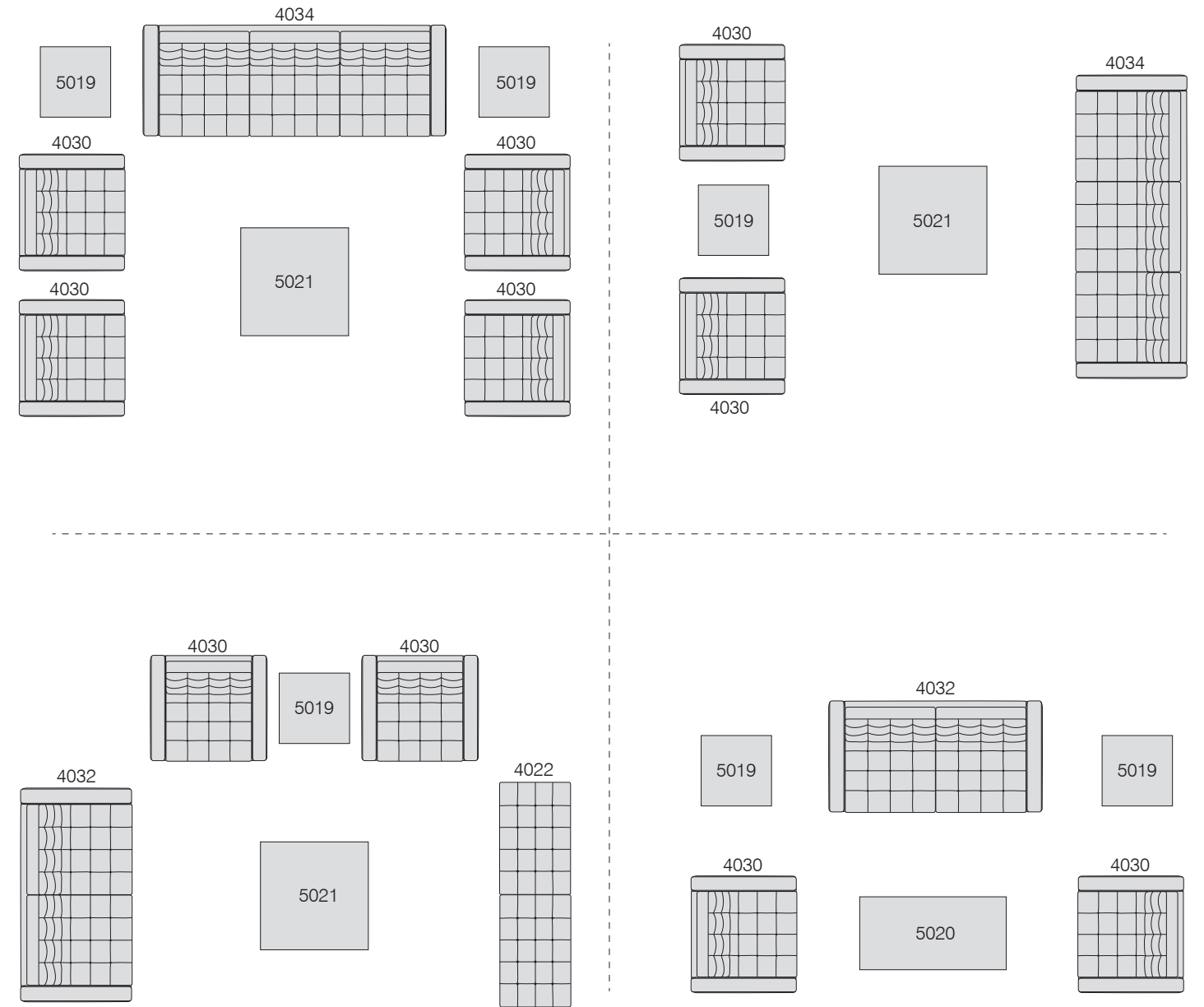



I prefer drawing to talking  
 Drawing is faster,  
 leaves less room  
 for lies



*Le Corbusier*



**1928** Lc2 chair



Barcelona chair **1929**



*Ludwig Mies Van Der Rohe*

A Chair is a very  
 difficult object  
 A skyscraper is  
 almost easier  
 That is why Chippendale  
 is famous

Good design  
 is Good Business



*Florence Knoll*



**1952** Florence chair



Eames chair **1956**



*Charles and Ray Eames*

The role of a  
 designer  
 is that of a very  
 good thoughtful  
 host anticipating  
 the need of  
 his guests



# Florence

b. Michigan, USA, 1917

Born to a baker, and orphaned at age twelve, Florence Schust grew up Saginaw, Michigan. Schust demonstrated an early interest in architecture and was enrolled at the Kingswood School for Girls, adjacent to the Cranbrook Academy of Art.

In 1941 Florence moved to New York where she met Hans Knoll who was establishing his furniture company. With Florence's design skills and Hans' business acumen and salesmanship, the pair, who married in 1946, grew the nascent company into an international arbiter of style and design. Florence also seeded contributions with her friends Eero Saarinen, Harry Bertoia, and Mies van der Rohe.

In creating the revolutionary Knoll Planning Unit, Florence Knoll defined the standard for the modern corporate interiors of post-war America. Drawing on her background in architecture, she introduced modern notions of efficiency, space planning, and comprehensive design to office planning.

As part of her work with the Planning Unit, Florence frequently contributed furniture designs to the Knoll catalog. She humbly referred to her furniture designs as the "meat and potatoes," filler among the standout pieces of Bertoia, Mies, and Saarinen. However, with her attention to detail, eye for proportion, and command of the modern aesthetic, many of her designs have become as revered and celebrated as those of her colleagues.

After the tragic death of Hans Knoll in 1955, Florence Knoll led the company as president through uncertain times. In 1960 she resigned the presidency to focus on directing design and development and, in 1965 after pioneering an industry and defining the landscape and aesthetic of the corporate office, Florence Knoll Bassett (she remarried in 1957) retired from the company. Her contributions to Knoll, and the rise of modernism in America, are immeasurable.



